

BF906 FITTING INSTRUCTIONS

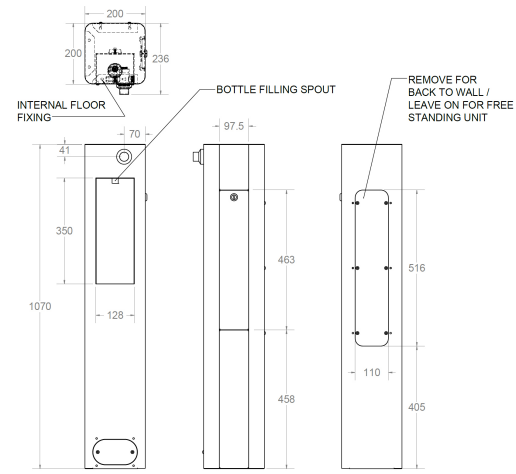

Remove rear access panel which is held on with 6 security screws. Discard panel if fixing to the rear wall - retain access panel for re-fitting later if using as a freestanding unit.

Remove side access door for access. Secured with a lock and key.

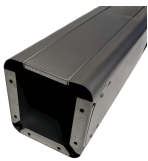

Fix the unit to the floor with suitable floor fixings (not supplied) through the fixing holes in the base. If the unit is to be fitted to the back wall you can utilise the rear access panel fixing holes to secure the unit to the back wall with suitable fixings (not supplied).



Dependant on your installation layout your supply and waste pipework will be arranged to connect through the back wall or the floor.

The waste fitting is pre-fitted and has a 32mm flexible waste pipe to allow easy fitting to the buildings waste pipework (a trap should be fitted to your pipework).

The water inlet is pre-fitted with flexible water pipe and a 1/2" female connector to allow easy fitting to the buildings water supply.

We recommend fitting a Y strainer to the inlet pipework and all pipework should be flushed before connecting to the unit. An isolating valve and drain down valve should be fitted if installed outside to allow isolation and drain down of the unit during the risk of freezing. All installations will need to comply with water supply installation regulations

Check all connections are watertight.

Replace the side access door and rear access panel (for free standing units).

Clean unit with warm soapy water and a cloth or stiff bristle brush. Further cleaning should be regularly undertaken with warm soapy water only. Chemical cleaners are not required or advised.